

HANGMAN

RP-E-2105



Rakumba

WWW.RAKUMBA.COM
SALES@RAKUMBA.COM

ALL RIGHTS RESERVED © RAKUMBA, 2021

Rakumba





The lights echo the gestural form of the "Hangman" game with a stick-figure-like personality. They have a typographic quality, which draws on the game's word-based mechanic and analogue interaction.

— Adam Goodrum





I wanted to distil the feeling of putting a pencil to a page, where the possibilities are endless. The range is about versatility, about your own imagination, to be used like a 3D drawing.

————— **Adam Goodrum**







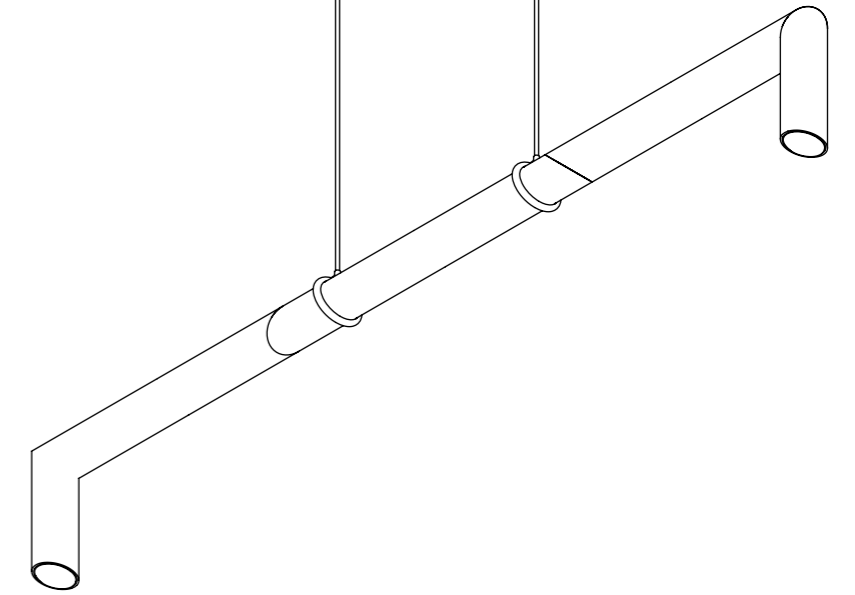

HANGMAN

RP-E-2105

A combination of mischievous nostalgia and avant-garde sculpture, Hangman is the first collaboration between Rakumba and esteemed Australian designer, Adam Goodrum. Inspired by the universally recognised analogue game of 'Hangman', this collection of floor, table and pendant luminaires embodies playful design and simple, yet magically executed geometry.

Comprising multiple articulated segments that swivel with an irresistible haptic action, each Hangman light is capable of a surprisingly acrobatic and visually intriguing range of positions. Pairing this directionality with the jewel-like polished glow of a high performance

LED optic tip, Hangman delivers unexpected functionality, channelling light to key points within a space while contributing its own iconic personality.

With a nod to the enduring materiality of ageless works by Ray and Charles Eames and Marc Newson, Hangman is available in finishes of anodised black and raw polished aluminium designed to elegantly patina over time.

Hangman: distilled nostalgia from daring geometries.

*The graphic simplicity of Hangman hides complex engineering
– an ambitious, paradoxical design problem resolved through
technical nous and desire to innovate.*

————— **Adam Goodrum**



Hangman channels light through a minimalist structure, while simultaneously allowing a high degree of functionality with numerous positions and light directions.

———— Adam Goodrum

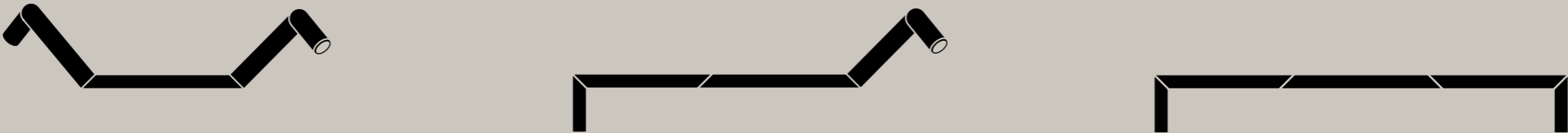
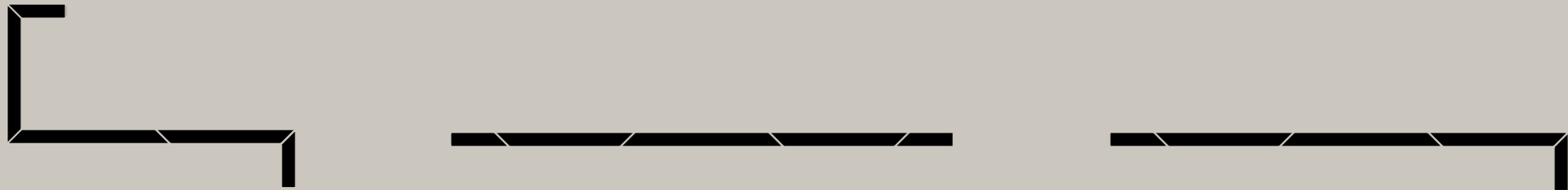
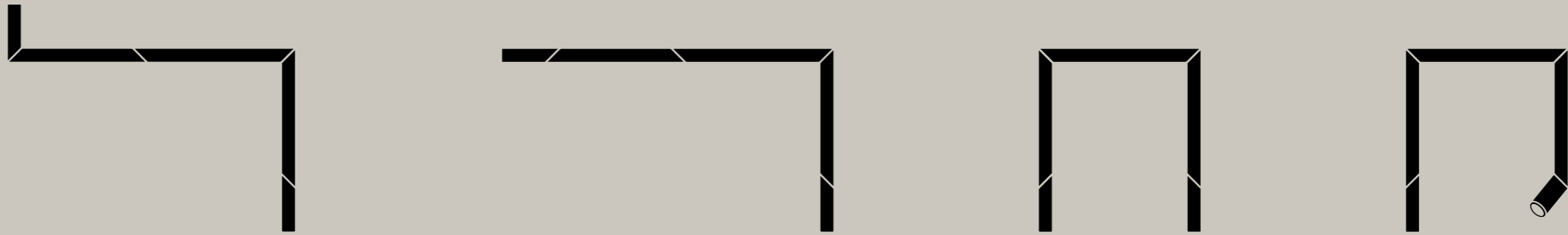
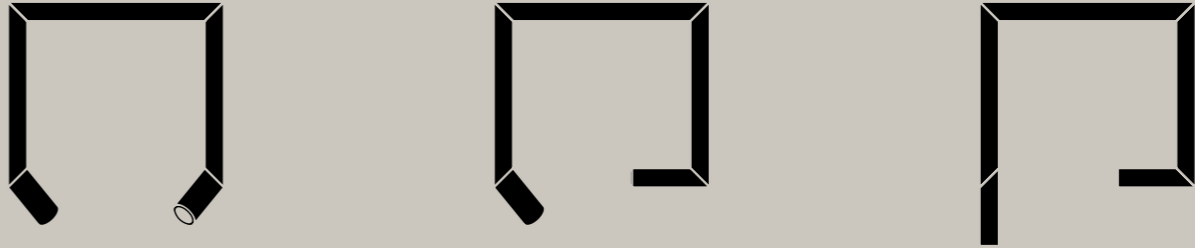

MATERIALS & FINISHES



BLACK ANODISED



POLISHED ALUMINIUM

MODELS

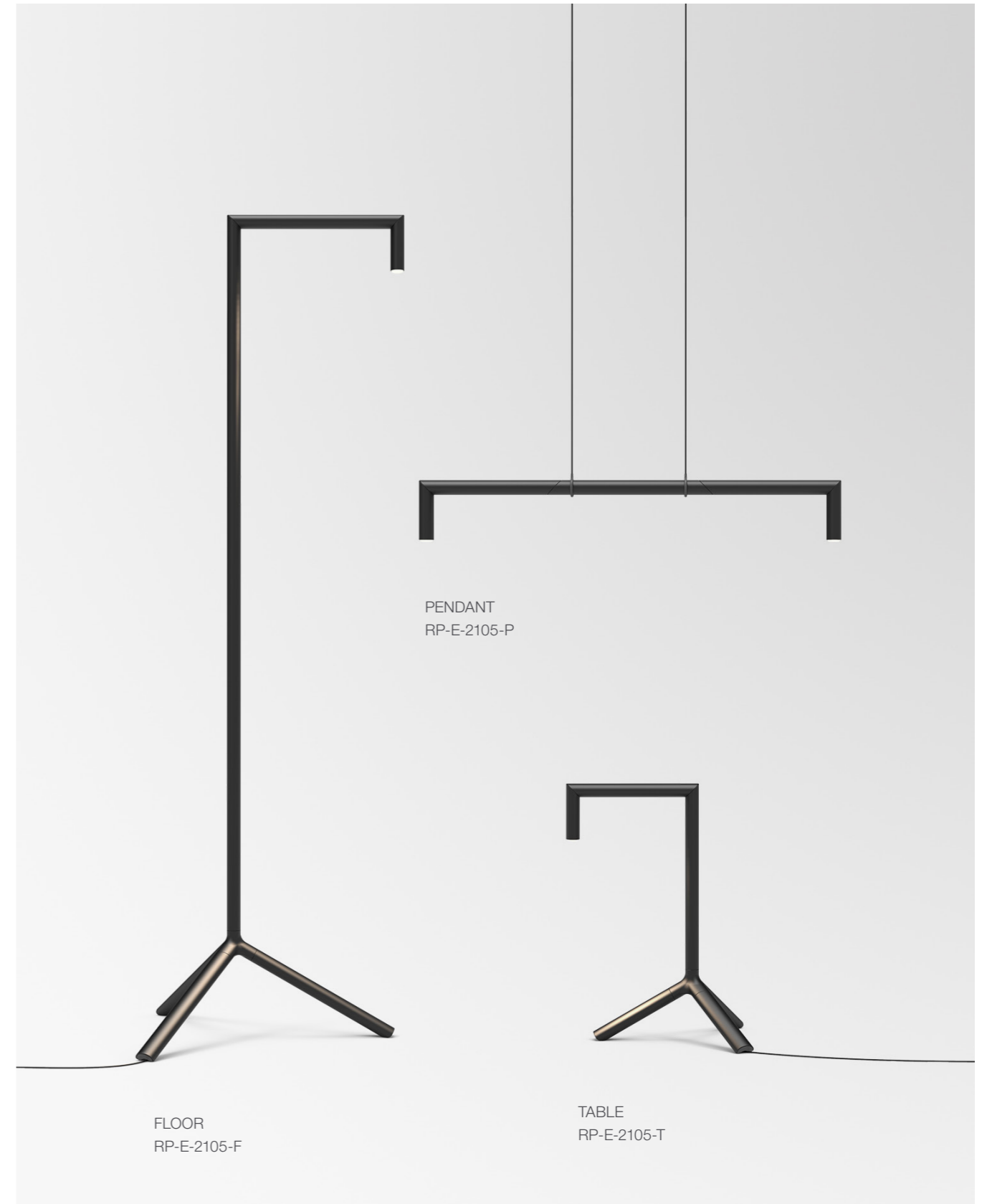

PENDANT
RP-E-2105-P

FLOOR
RP-E-2105-F

TABLE
RP-E-2105-T

HANGMAN SWIVEL

USER ADJUSTABLE POSITIONING

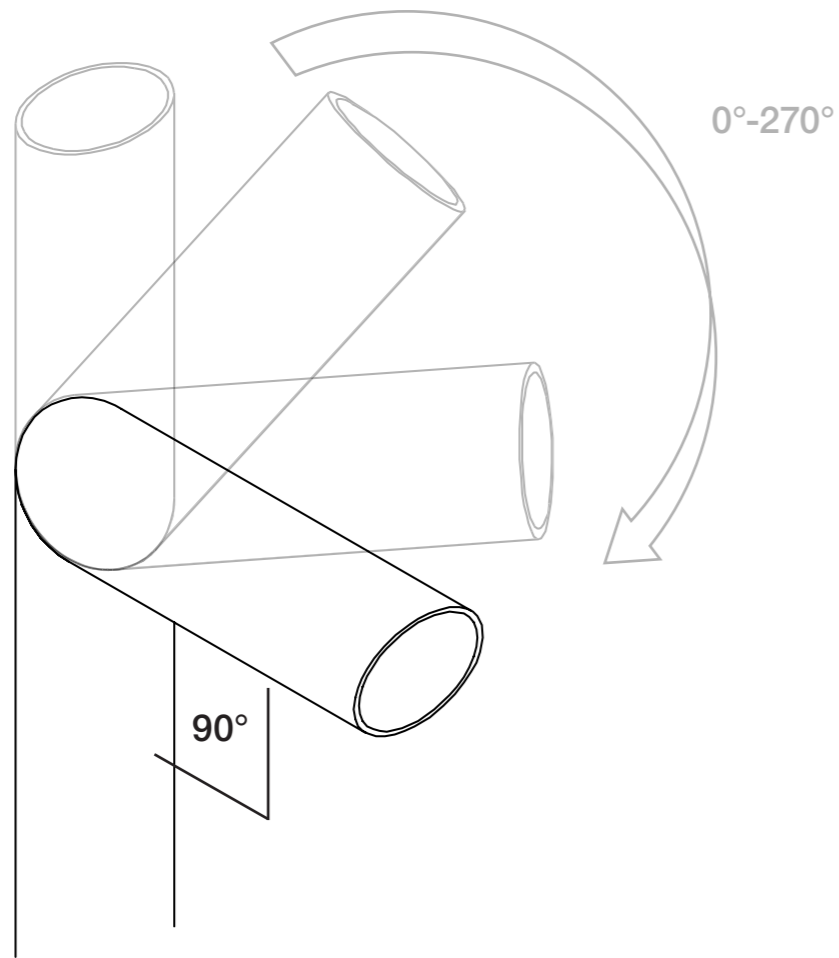

SWIVEL SYSTEM
EACH ARM SEGMENT ADJUSTS FROM A
0° - 90° ANGLE AS THE JOINT IS ROTATED
(ROTATION RANGE 0° - 270°)

SWIVEL SYSTEM ON EACH PRODUCT

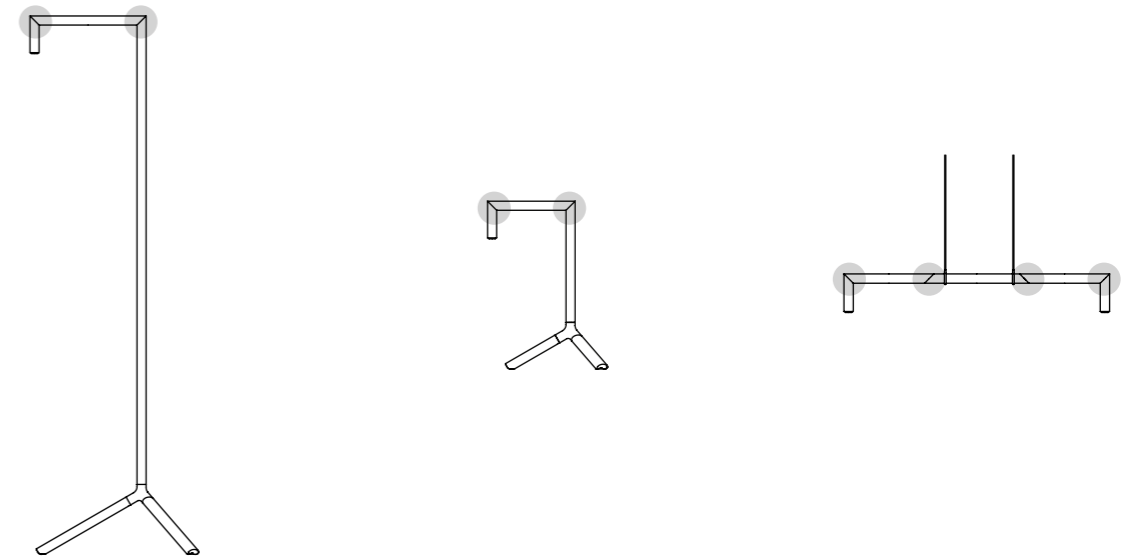

VARIOUS ORIENTATIONS

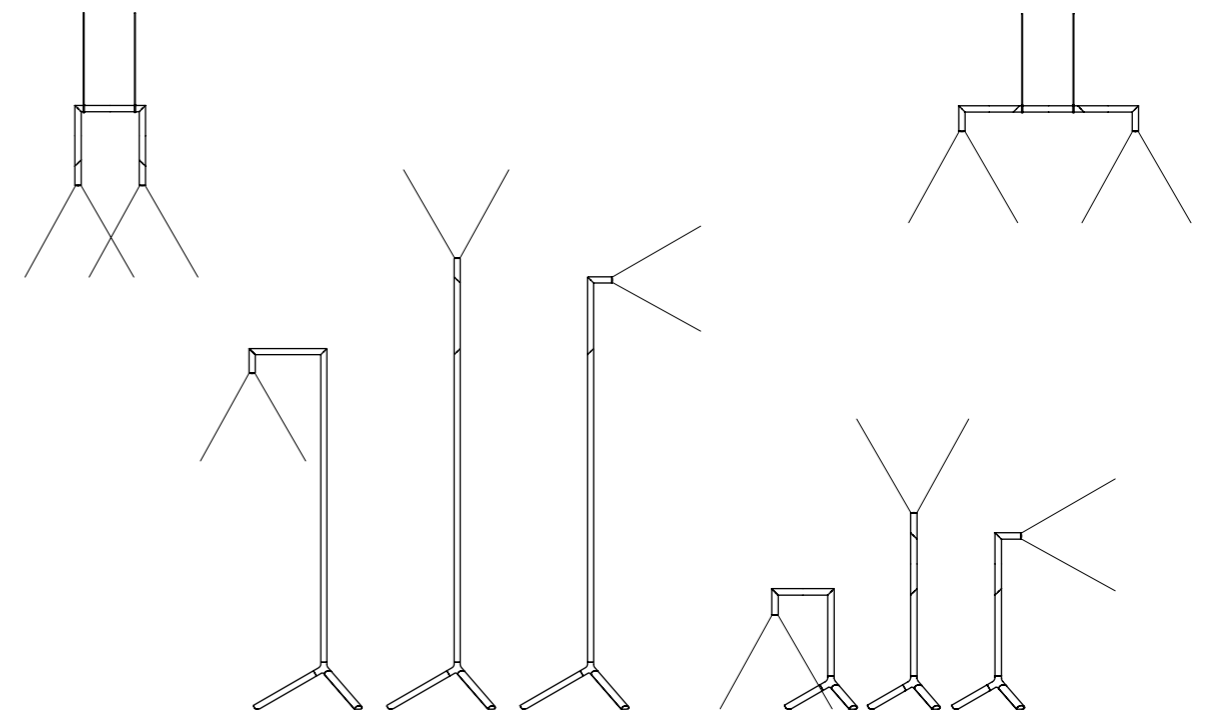

DIMENSIONS

FLOOR

ALL DIMENSIONS IN MILLIMETERS

PENDANT

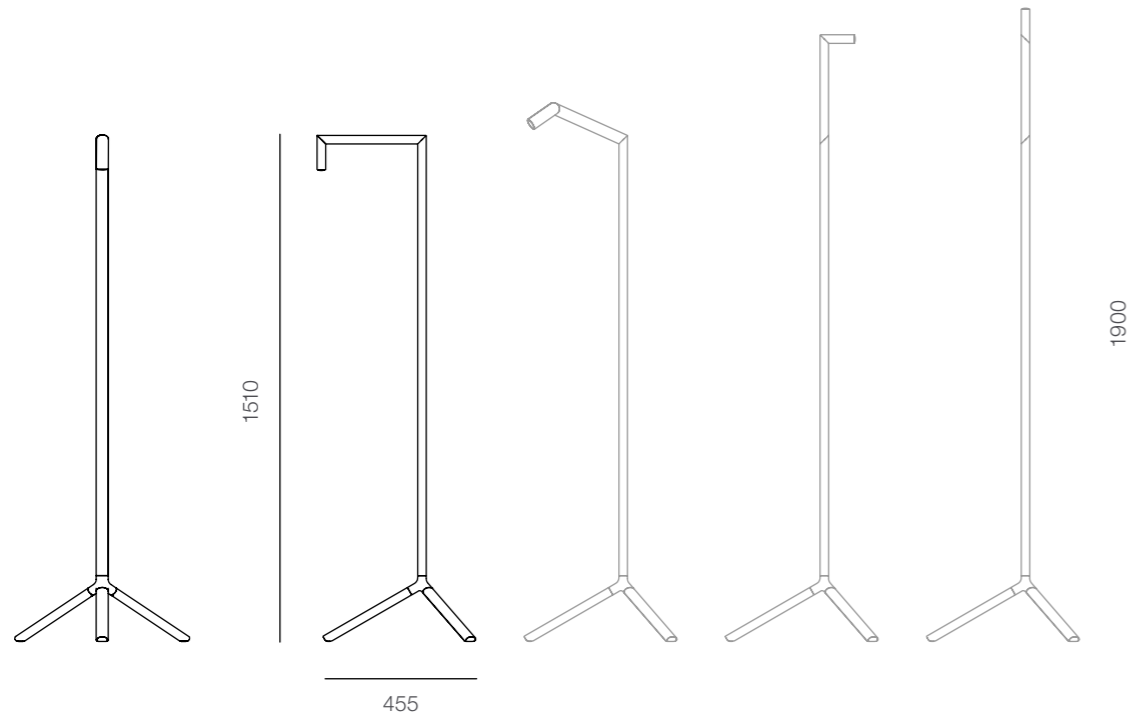

PRIMARY ORIENTATIONS

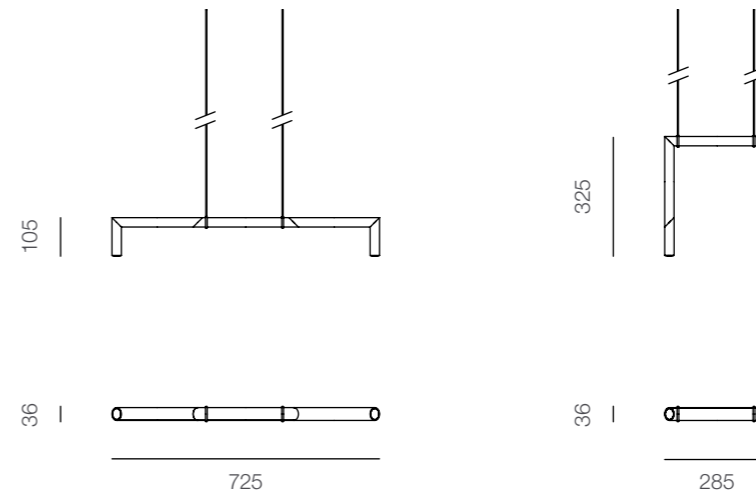

ORIENTATION POSSIBILITIES (USER ADJUSTABLE)

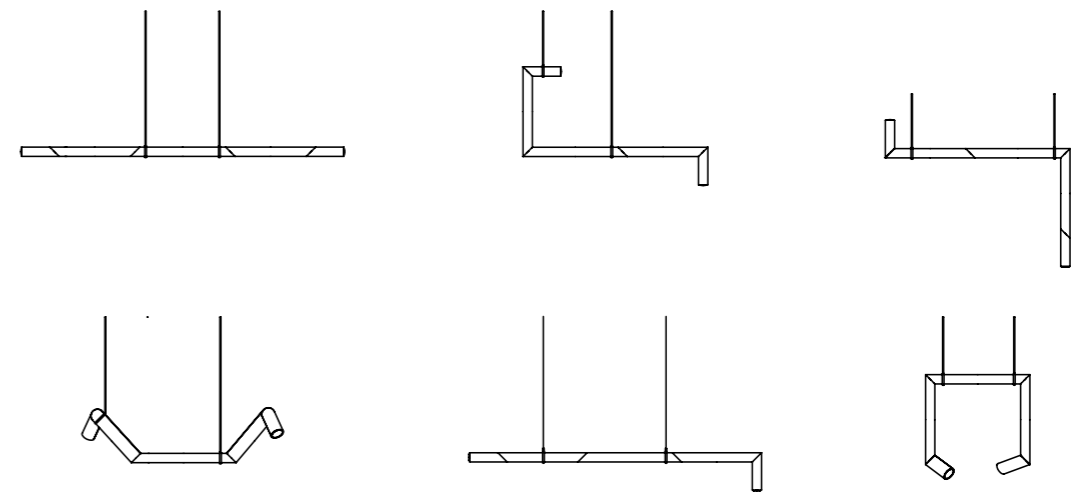

TABLE

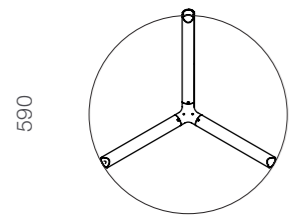

590

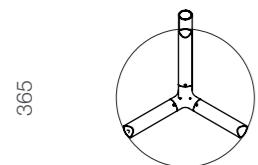
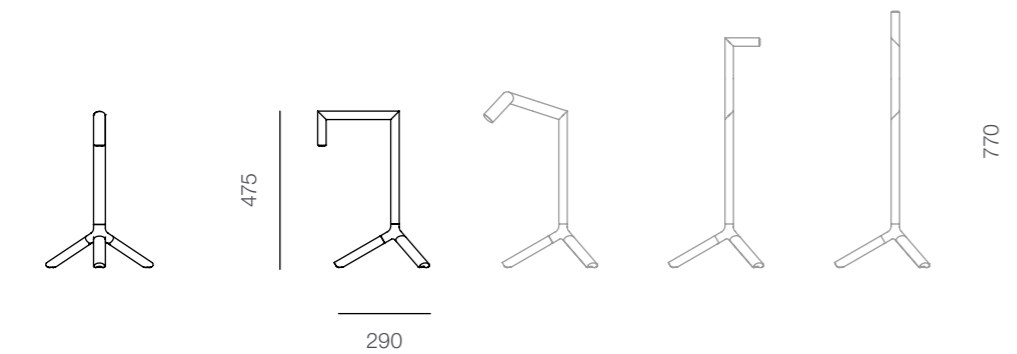

365

OPTIONS

PENDANT

FINISH	<input type="radio"/> BLACK ANODISED <input type="radio"/> POLISHED ALUMINIUM
BEAM ANGLE	<input type="radio"/> 60° (STANDARD) <input type="radio"/> 30° (ON REQUEST)
DIMMING	<input type="radio"/> PHASE CUT/TRIAC (REMOTE DRIVER) <input type="radio"/> DALI/SWITCH-DIM (REMOTE DRIVER)
SUSPENSION LENGTH	<input type="radio"/> 2M <input type="radio"/> 5M <input type="radio"/> CUSTOM (MAX 10M)
SEAMLESS CANOPY	<input type="radio"/> BLACK <input type="radio"/> WHITE <input type="radio"/> SILVER
DIMMING	<input type="radio"/> PHASE CUT/TRIAC (REMOTE DRIVER) <input type="radio"/> DALI/SWITCH-DIM (REMOTE DRIVER)

FLOOR AND TABLE LAMP

FINISH	<input type="radio"/> BLACK ANODISED <input type="radio"/> POLISHED ALUMINIUM
BEAM ANGLE	<input type="radio"/> 60° (STANDARD) <input type="radio"/> 30° (ON REQUEST)
DIMMING	<input type="radio"/> CORDSET PUSH DIMMER
PLUG	<input type="radio"/> AU <input type="radio"/> EU <input type="radio"/> UK <input type="radio"/> US

DATA

RP-E-2105	PENDANT	FLOOR	TABLE
LIGHTSOURCE	INTEGRATED LED		
POWER	13W	6.3W	6.3W
LUMENS (SOURCE)	1050lm	500lm	500lm
LUMENS (DELIVERED)	-	-	-
COLOUR TEMPERATURE	2700K		
CRI	CRI90		
PRIMARY VOLTAGE (TO DRIVER)	220-240VAC		
SECONDARY CURRENT (TO FITTING)	1050mA CONSTANT CURRENT	500mA CONSTANT CURRENT	500mA CONSTANT CURRENT
PRODUCT WEIGHT	1kg	2kg	1.3kg
PACKED WEIGHT	3.5kg	5.5kg	4kg
PACKED DIMENSIONS	ø100 x920mm	ø100 x1980mm	ø100 x1150mm
DRIVER LOCATION	REMOTE	CORDSET	CORDSET
IP RATING	IP20		
L70	50,000 HOURS		
APPROVALS	AUSTRALIA, EUROPE		





ADAM GOODRUM

Adam Goodrum founded his Sydney design studio in 2006. One of Australia's most recognised contemporary object artists, his practice is characterised by invention and curiosity, while his approach is inflected with rigour and integrity.

Focusing on furniture, product and collectible design, his work is inherently elegant, often underpinned by a poetic union between art and mathematics.

The recipient of every major Australian design accolade, he has worked internationally with Alessi, Cappellini, Kvadrat and Louis Vuitton. Adam's work has been showcased throughout the world and is collected by museums in both Australia and internationally.